

Double Pallet Decoiler DHPB-1500

Innovative Winding Technology for Double Material Feeding



Perfect Technology

- Speed-controlled strip pullers
- Dancer-controlled turntables
- High load carrying capacity due to rugged welded construction
- Material tension query for tool protection
- Siemens text display of operating messages
- Siemens control system
- Gentle and tensionless decoiling
- Strip end detector for automatic stop of press
- Easy operation
- Contactless loop control with visible infrared light

- Alternating Winding -
Coiling on one level, preparing for punching
or welding on the other

Technical Data

Double Pallet Decoiler DHPB-1500

Optional Accessories

- Wider strip pullers
- Precision straighteners
- Support arm for strip thickness ≥ 1 mm
- Various table diameters
- Material clamping system
- Speed-controlled paper coiler for tearable paper
- Contactless loop control with ultrasound for material speeds ≥ 25 m/min

Dancer control



Speed-controlled strip puller

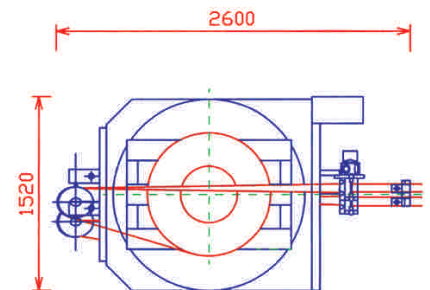
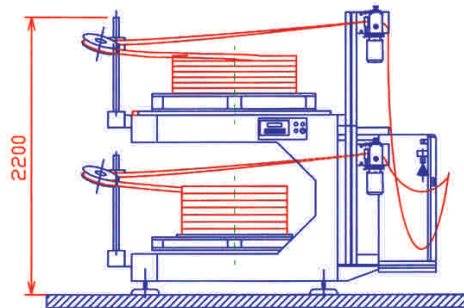

Control panel

Model	DHPB-1500	DHPB-1600
Turntable	Ø 1500 mm	Ø 1600 mm
Loading capacity	2 x 3000 kg	2 x 3000 kg
Speed	Standard 25 m/min	Standard 25 m/min
Direction of rotation	Both sides	Both sides
Material width, max.	Standard 80 mm	Standard 80 mm
Material thickness, max.	Standard approx. 1 mm	Standard approx. 1 mm
Electrical connection	3 x 400 V, N + PE 50 Hz/16 A	3 x 400 V, N + PE 50 Hz/16A
Dimensions (L x W x H) in mm	2600 x 1520 x 2200	2700 x 1620 x 2200

HURAS AUTOMATION GMBH
 Boschstrasse 10
 75236 Kaempfelbach-Bilfingen
 Germany

Phone: +49 (7232) 31-5802
 Fax: +49 (7232) 31-5803

E-mail: huras@huras-automation.de
www.huras-automation.de