

Double Pallet Decoiler with Straighteners DHPR-1500

Innovative Winding Technology for Highest Requirements



Perfect Technology

- Speed-controlled precision straighteners
- Dancer-controlled turntables
- High load carrying capacity due to rugged welded construction
- Synchronous drive of the lower straightening rollers and the pulling roller
- Material tension query for tool protection
- Gentle and tensionless decoiling
- Strip end detector for automatic stop of press
- Easy operation
- Siemens text display for operating messages
- Siemens control system
- Contactless loop control with visible infrared light
- Easy cleaning of straightening rollers and drive roll

Technical Data

Double Pallet Decoiler with Straighteners DHPR-1500

Optional Accessories

- Wider precision straighteners (up to 350 mm)
- Support arm for strip thickness ≥ 1 mm
- Material clamping system
- Various table diameters
- Speed-controlled paper coiler for tearable paper
- Contactless loop control with ultrasound for material speeds ≥ 25 m/min



Easy cleaning of the straightening rollers

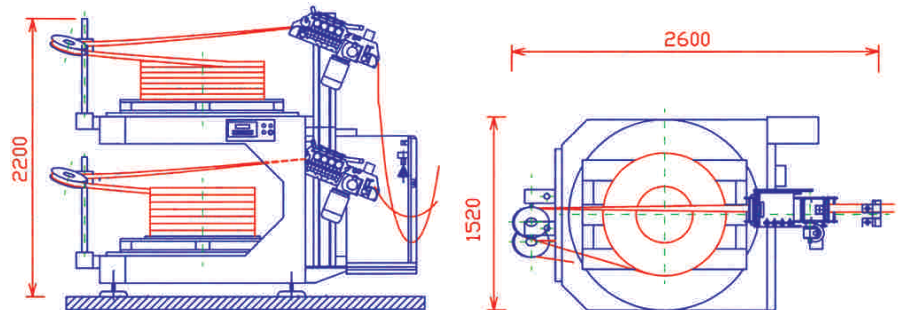

Dancer arm

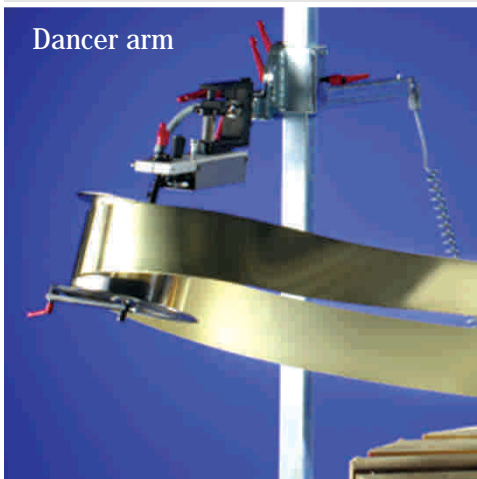

Model	DHPR-1500
Turntable	Ø 1500 mm
Loading capacity	2 x 3000 kg
Speed	Standard 25 m/min
Direction of rotation	Both sides
Material width, max.	Standard 130 mm
Material thickness, max.	0.2 mm to 1.5 mm
Number of straightening rollers	9 (4 upper, 5 lower)
Straightening roller diameter	Ø 40 mm
Electrical connection	3 x 400 V, N + PE 50 Hz/16 A
Dimensions (L x W x H) in mm	2600 x 1500 x 2200



Control panel

HURAS AUTOMATION GMBH
 Boschstrasse 10
 75236 Kaempfelbach-Bilfingen
 Germany

Phone: +49 (7232) 31-5802
 Fax: +49 (7232) 31-5803

E-mail: hurst@hurst-automation.de
www.hurst-automation.de