

# Pallet Decoiler with Dancer Arm HP-1500

Innovative Winding Technology for Reliable Operation

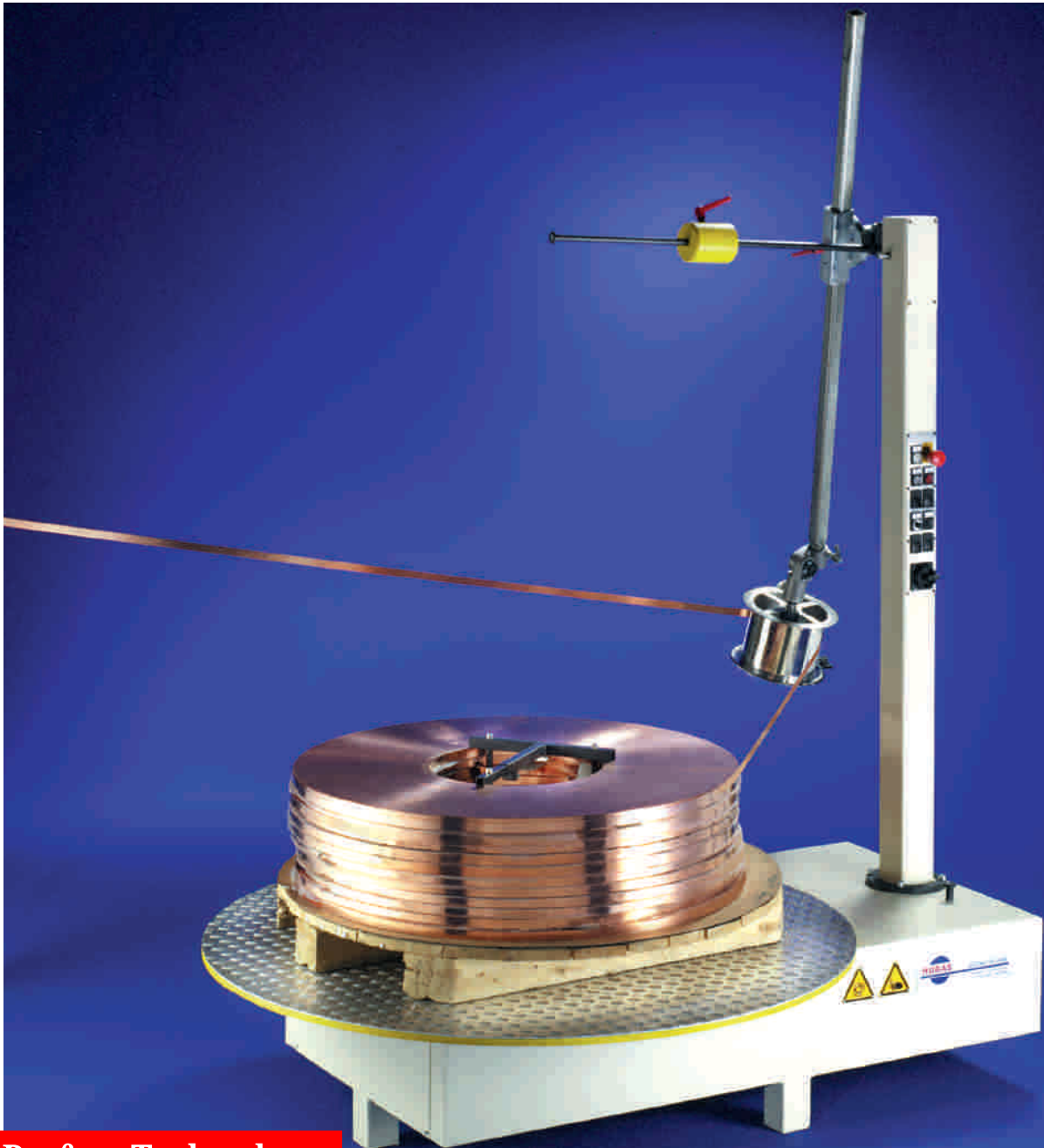

## Perfect Technology

- Dancer-controlled turntable
- High load carrying capacity due to rugged welded construction
- Material tension query for tool protection
- Easy operation
- Optimized tension adjustment with counterweight

## Technical Data

### Pallet Decoiler with Dancer Arm HP-1500

#### Optional Accessories

- Support arm for material thicknesses  $\geq 1$  mm
- Material clamping system
- Speed-controlled paper coiler for tearable paper

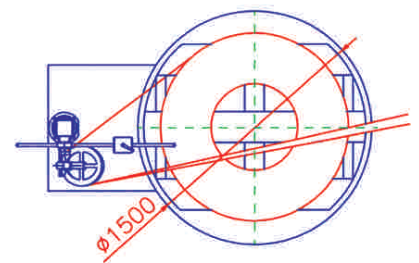
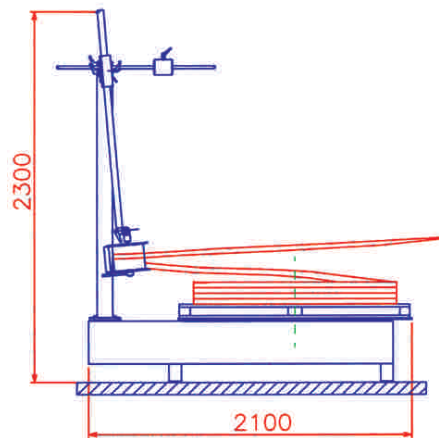

Model	HP-1200	HP-1500	HP-1600
Turntable	Ø 1200 mm	Ø 1500 mm	Ø 1600 mm
Loading capacity	3000 kg	3000 kg	3000 kg
Speed	Standard 25 m/min	Standard 25 m/min	Standard 25 m/min
Direction of rotation	Both sides	Both sides	Both sides
Material width, max.	Standard 150 mm	Standard 150 mm	Standard 150 mm
Material thickness, max.	1.5 mm	1.5 mm	1.5 mm
Electrical connection	3 x 400 V, N + PE 50 Hz/16 A	3 x 400 V, N + PE 50 Hz/16A	3 x 400 V, N + PE 50 Hz/16A
Dimensions (L x W x H) in mm	1800 x 1200 x 2300	2100 x 1500 x 2300	2200 x 1600 x 2300

HURAS AUTOMATION GMBH  
 Boschstrasse 10  
 75236 Kaempfelbach-Bilfingen  
 Germany

Phone: +49 (7232) 31-5802  
 Fax: +49 (7232) 31-5803

E-mail: [huras@huras-automation.de](mailto:huras@huras-automation.de)  
[www.huras-automation.de](http://www.huras-automation.de)