

Pallet Decoiler with Strip Puller HPB-1500

Innovative Winding Technology for Practical Material Transport



Perfect Technology

- Speed-controlled strip puller
- Dancer-controlled turntable
- High load carrying capacity due to rugged welded construction
- Material tension query for tool protection
- Gentle and tensionless decoiling
- Strip end detector for automatic stop of press
- Easy operation
- Contactless loop control with visible infrared light
- Quick-change drive roll system

Technical Data

Pallet Decoiler with Strip Puller HPB-1500

Optional Accessories

- Wider strip pullers
- Support arm for strip thickness ≥ 1 mm
- Various table diameters
- Material clamping system
- Speed-controlled paper coiler for tearable paper
- Contactless loop control with ultrasound for material speeds ≥ 25 m/min

Dancer control



Speed-controlled strip puller

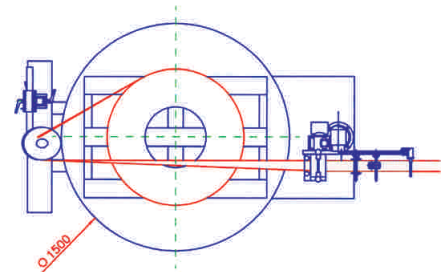
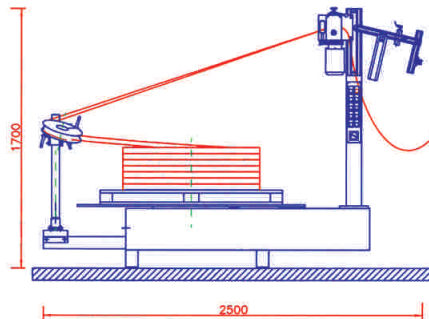
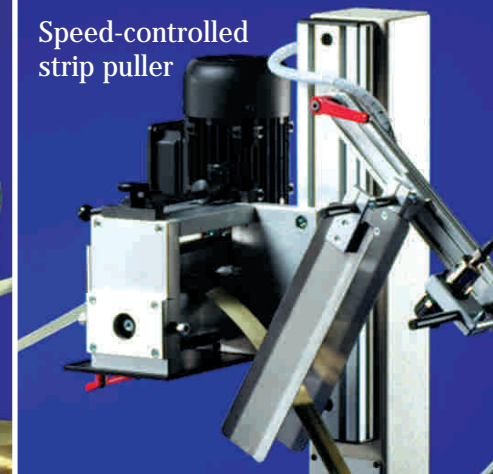

Model	HPB-1200	HPB-1500	HPB-2000
Turntable	Ø 1200 mm	Ø 1500 mm	Ø 2000 mm
Loading capacity	3000 kg	3000 kg	3000 kg
Speed	Standard 25 m/min	Standard 25 m/min	Standard 35 m/min
Direction of rotation	Both sides	Both sides	Both sides
Material width, max.	Standard 100 mm	Standard 100 mm	Standard 100 mm
Material thickness, max.	Standard approx. 1 mm	Standard approx. 1 mm	Standard approx. 1 mm
Electrical connection	3 x 400 V, N + PE 50 Hz/16 A	3 x 400 V, N + PE 50 Hz/16A	3 x 400 V, N + PE 50 Hz/16A
Dimensions (L x W x H) in mm	2250 x 1200 x 1700	2500 x 1500 x 1700	3100 x 2000 x 1700

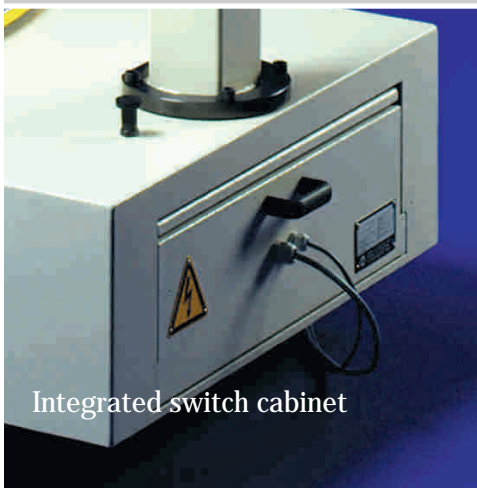

Integrated switch cabinet

HURAS AUTOMATION GMBH
 Boschstrasse 10
 75236 Kaempfelbach-Bilfingen
 Germany

Phone: +49 (7232) 31-5802
 Fax: +49 (7232) 31-5803

E-mail: huras@huras-automation.de
www.huras-automation.de